

STRAINER/FILTER type F10M
IN CARBON STEEL AND STAINLESS STEEL

PN16-40
DN15-DN200



FEATURES

Dirt trap/Filter in angle version with body and bonnet in cast steel or ductile iron. Filter element in plait non-corrosive-(304) or stainless (316) wire. Standard version with flanged or weld-end connection. Other connection types can be delivered.

APPLICATION

Water, steam, and other medium which not damage the internal components
Used in process industry, power plants, marine applications, etc.

Table 1 - Technical data

Dimensions	DN 15 to DN 200
Materials	Carbon steel, alloy steel, stainless steel, stainless steel,
Pressure class	PN 16 to PN 40
Temperature range	Carbon steel -20°C to max 400°C ¹⁾ Stainless to max 550°C ¹⁾
Connection forms	Flanged, cast iron Weld-ends, forged steel ≤ DN 50 Cast iron >DN 65
Filter	SS304, SS316 DN ≤ 65 0,8mm; DN >65 1,12mm

Standard

Design	EN 12516
Face-to-face	EN 558-1, 14
Flanges	EN 1092-1
Labelling	EN 19
Pressure test	EN 12266-1
CE-certified	acc. to PED97/23, Category

Table 2 - Pressure and temperature range according to EN 1092-1, PN16 - PN25/40

Material body	PN	RT	100	150	200	250	300	350	400	450	500	530	550 ¹⁾
Carbon steel 1.0619	16	16,0	14,9	13,9	12,4	11,4	10,3	9,6	9,2				
Carbon steel 1.0619	25/40	40,0	37,3	34,7	30,2	28,4	25,8	24,0	23,1				
Alloy steel 1.5419	25/40	40,0	40,0	40,0	38,2	35,6	30,2	28,4	26,7	25,8	18,0		
Alloy steel 1.7357		40,0	40,0	40,0	40,0	39,1	36,4	33,8	32	30,2	24,4	13,9	
Stainless steel CF8	16	14,7	12,1	11,0	10,2	9,6	9,0	8,7	8,4	8,1	7,8	7,6	7,3
Stainless steel CF8M		14,7	12,5	11,4	10,6	9,8	9,3	9,0	8,7	8,5	8,4	8,3	8,2
Stainless steel CF8	25/40	36,8	30,3	27,5	25,5	24,1	22,7	21,9	21,2	20,3	19,6	19,2	18,4
Stainless steel CF8M		36,8	31,3	28,5	26,4	24,7	23,4	22,6	21,8	21,4	21,0	20,8	20,7

1) För flänsade ventiler max 530°C

STRAINER/FILTER type F10M
IN CARBON STEEL AND STAINLESS STEEL

PN16-40
DN15-DN200

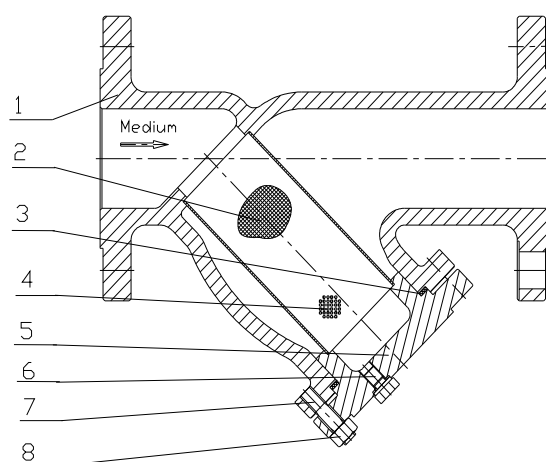
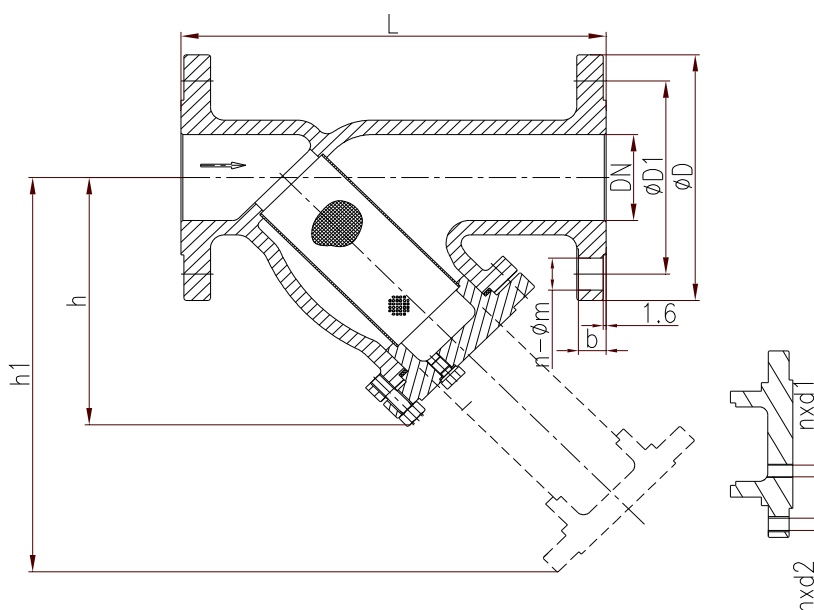

Table 3. Material specification

Pos	Part	Material		
1	Hus	1.0619	CF8	CF8M
2	Support cage	SS 304	SS 304	SS 316
3	Packing	Grafit	Grafit + 304	Grafit + 304
4	Filter element	SS 304 SS 316	SS 304 SS 316	SS 316
5	Bonner	1.0619	CF8	CF8M
6	Drain plug	ASTM 1025	ASTM 1025	ASTM 1025
7	Bolt	carbon steel	carbon steel	carbon steel
8	Mutter	ASTM A 194 2H	ASTM A 194 2H	ASTM A 194 2H



STRAINER/FILTER type F10M
IN CARBON STEEL AND STAINLESS STEEL

PN16-40
DN15-DN200



Table 4. Dimensions

DN	PN	L mm	D mm	D1 mm	b mm	h mm	h1 mm	n-Φm mm
15		130	95	65	16	98	156	4x14
20		150	105	75	18	103	164	4x14
25	16-25/40	160	115	85	18	108	172	4x14
32		180	140	100	18	115	183	4x18
40		200	150	110	18	140	223	4x18
50		230	165	125	18	155	247	4x18
65		290	185	145	18	198	316	8x18
80		310	200	160	20	210	335	8x18
100	16	350	220	180	20	250	398	8x18
125		400	250	210	22	305	486	8x18
150		480	285	240	22	358	571	8x22
200		600	340	295	24	450	717	12x22
50		230	165	125	20	150	239	4x18
65		290	185	145	22	175	279	8x18
80	25/40	310	200	160	24	205	327	8x18
100		350	235	190	24	245	390	8x22
125		400	270	220	26	285	454	8x26
150		480	300	250	28	335	534	8x26
200	25	600	360	310	30	415	661	12x26
200	40	600	375	320	34	415	661	12x30

Table 5. Product codes - valves of carbon steel

PN	Connection	Material body 1,0619		Material body 1,7357	
		Filter SS304	Filter SS316	Filter SS304	Filter SS316
16	Flange	F10M37*YF016-zzz**	F10M38*YF016-zzz**	F10M48*YF016Y-zzz**	F10M58*YF016Y-zzz**
16	Weld-ends DN15-DN50 Forged	F20M37*YB016Y-zzz**	F20M38*YB016Y-zzz**	F20M48*YB016Y-zzz**	F20M58*YB016Y-zzz**
16	Weld-ends > DN 50 Casted	F10M37*YB016Y-zzz**	F10M38*YB016Y-zzz**	F10M48*YB016Y-zzz**	F10M58*YB016Y-zzz**
25	Flange	F10M37*YF025Y-zzz**	F10M38*YF025Y-zzz**	F10M48*YF025Y-zzz**	F10M58*YF025Y-zzz**
25	Weld-ends DN15-DN50 Forged	F20M37*YB025Y-zzz**	F20M38*YB025Y-zzz**	F20M48*YB025Y-zzz**	F20M58*YB025Y-zzz**
25	Weld-ends > DN 50 Casted	F10M37*YB025Y-zzz**	F10M38*YB025Y-zzz**	F10M48*YB025Y-zzz**	F10M58*YB025Y-zzz**
40	Flange	F10M37*YF040Y-zzz**	F10M38*YF040Y-zzz**	F10M48*YF040Y-zzz**	F10M58*YF040Y-zzz**
40	Weld-ends DN15-DN50 Forged	F20M37*YB040Y-zzz**	F20M38*YB040Y-zzz**	F20M48*YB040Y-zzz**	F20M58*YB040Y-zzz**
40	Weld-ends > DN 50 Casted	F10M37*YB040Y-zzz**	F10M38*YB040Y-zzz**	F10M48*YB040Y-zzz**	F10M58*YB040Y-zzz**

Address EF Valves AB
Teknikringen 1F
583 30 Linköping
Sweden

Contact: +46 (0) 703 22 56 36
info@efvalves.se
www.efvalves.se